

SECTION A-A

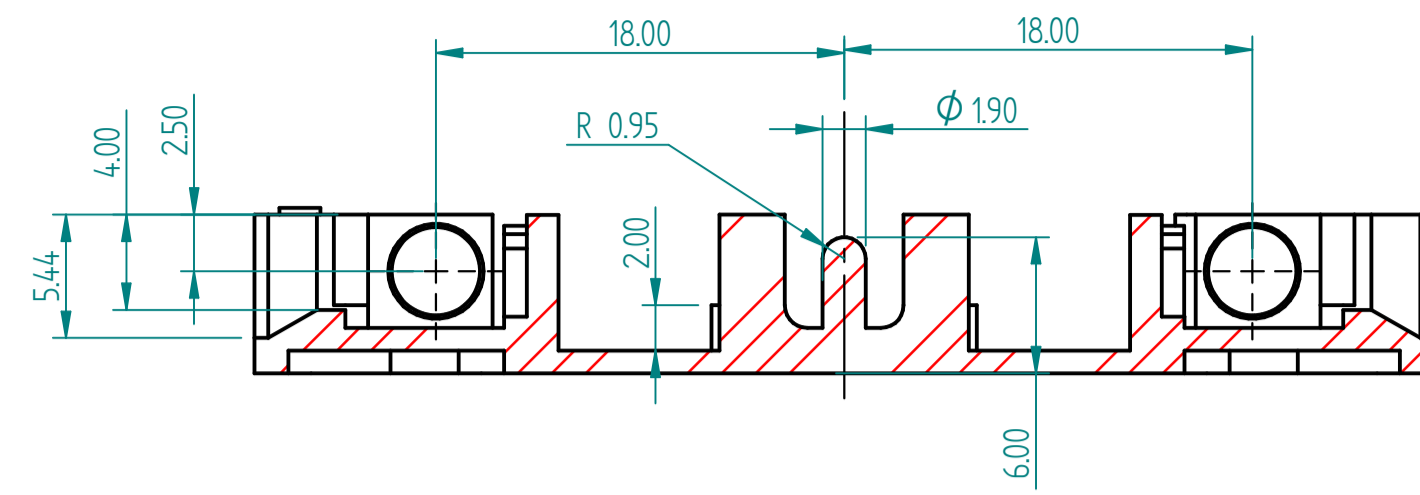

SECTION B-B

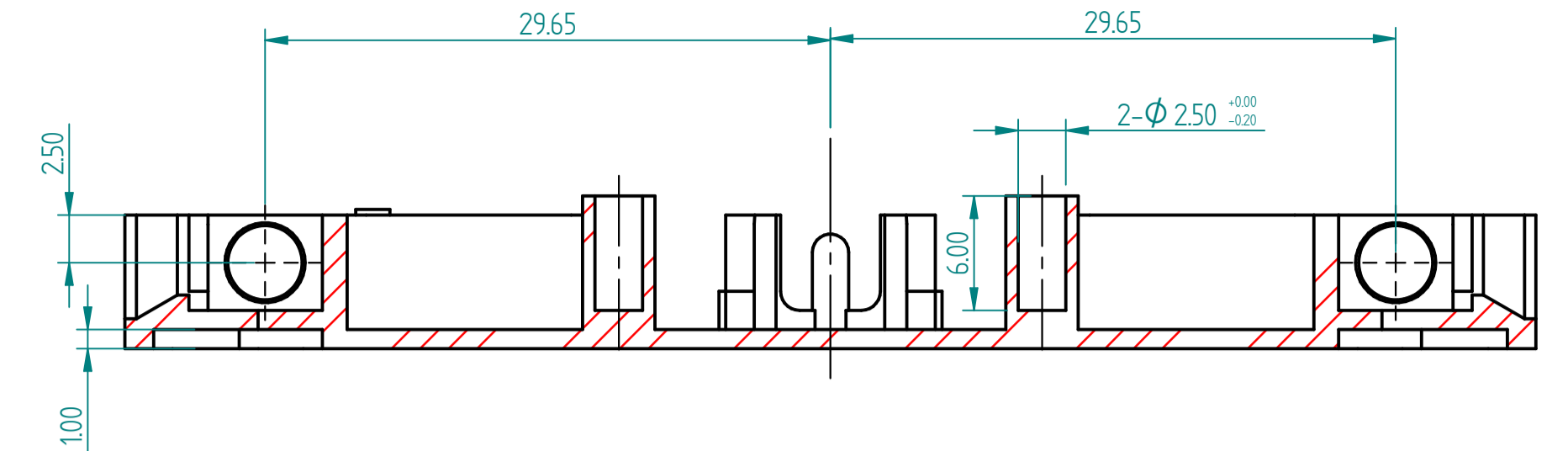

SECTION C-C

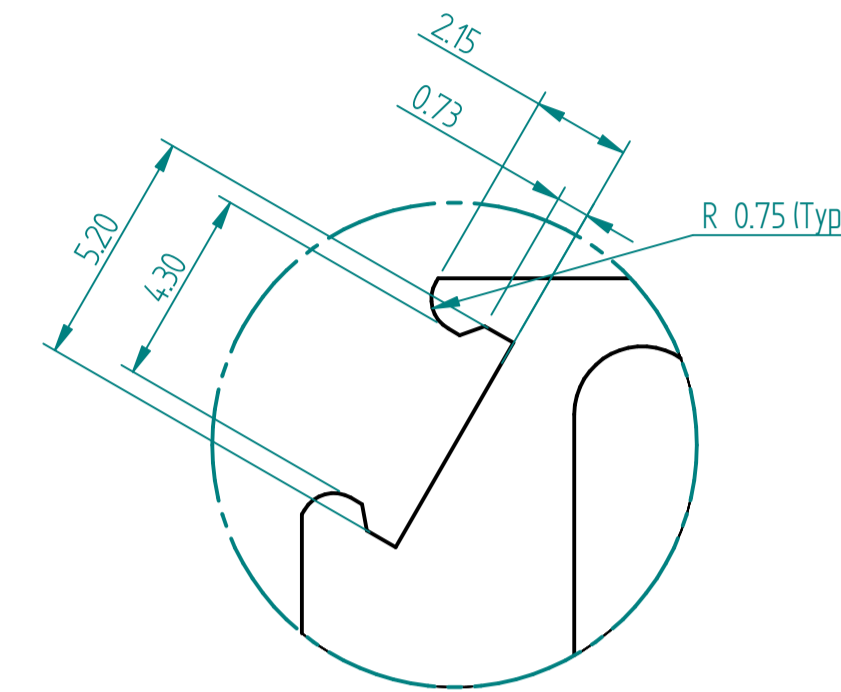

DETAIL F

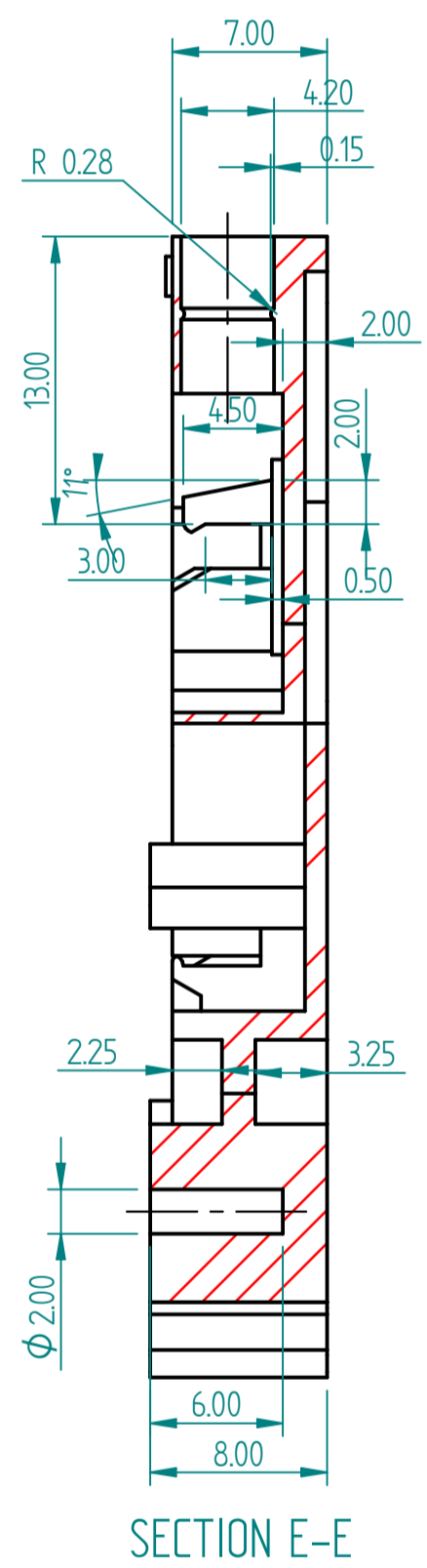

SECTION E-E

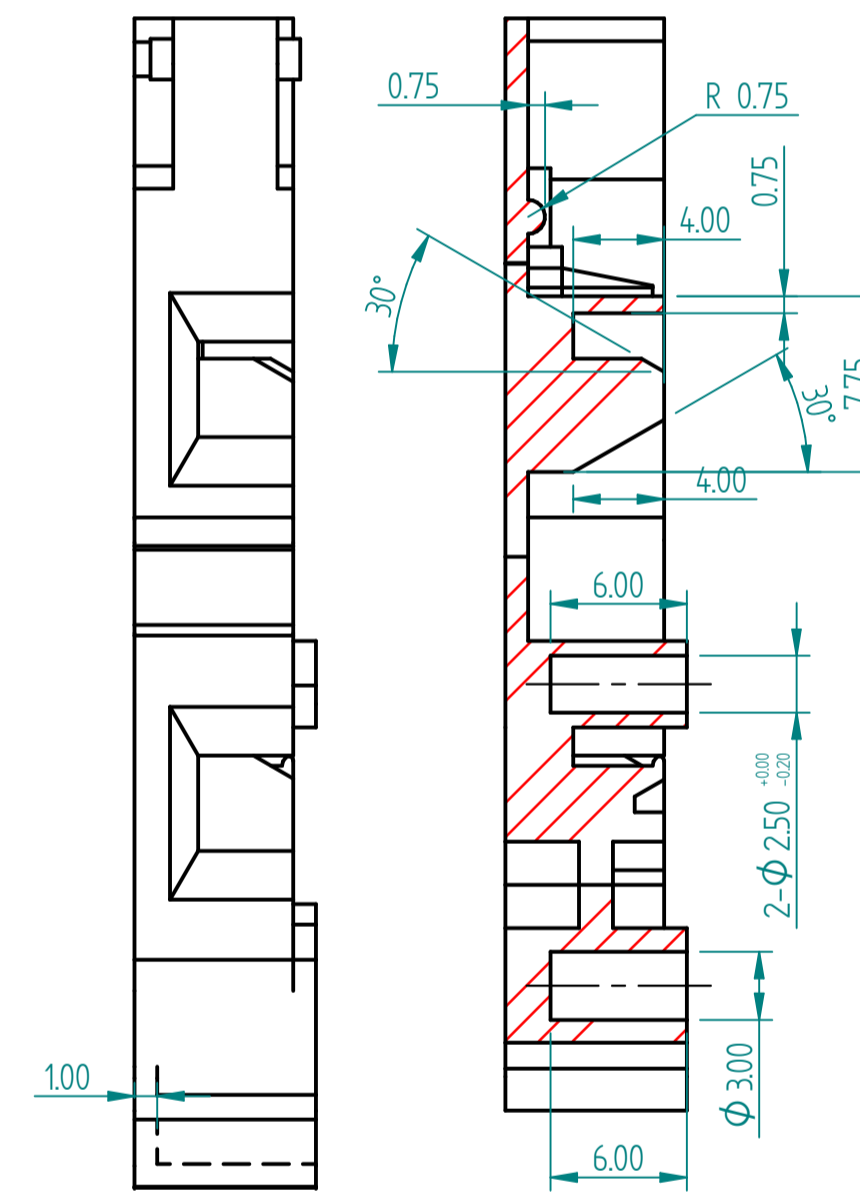
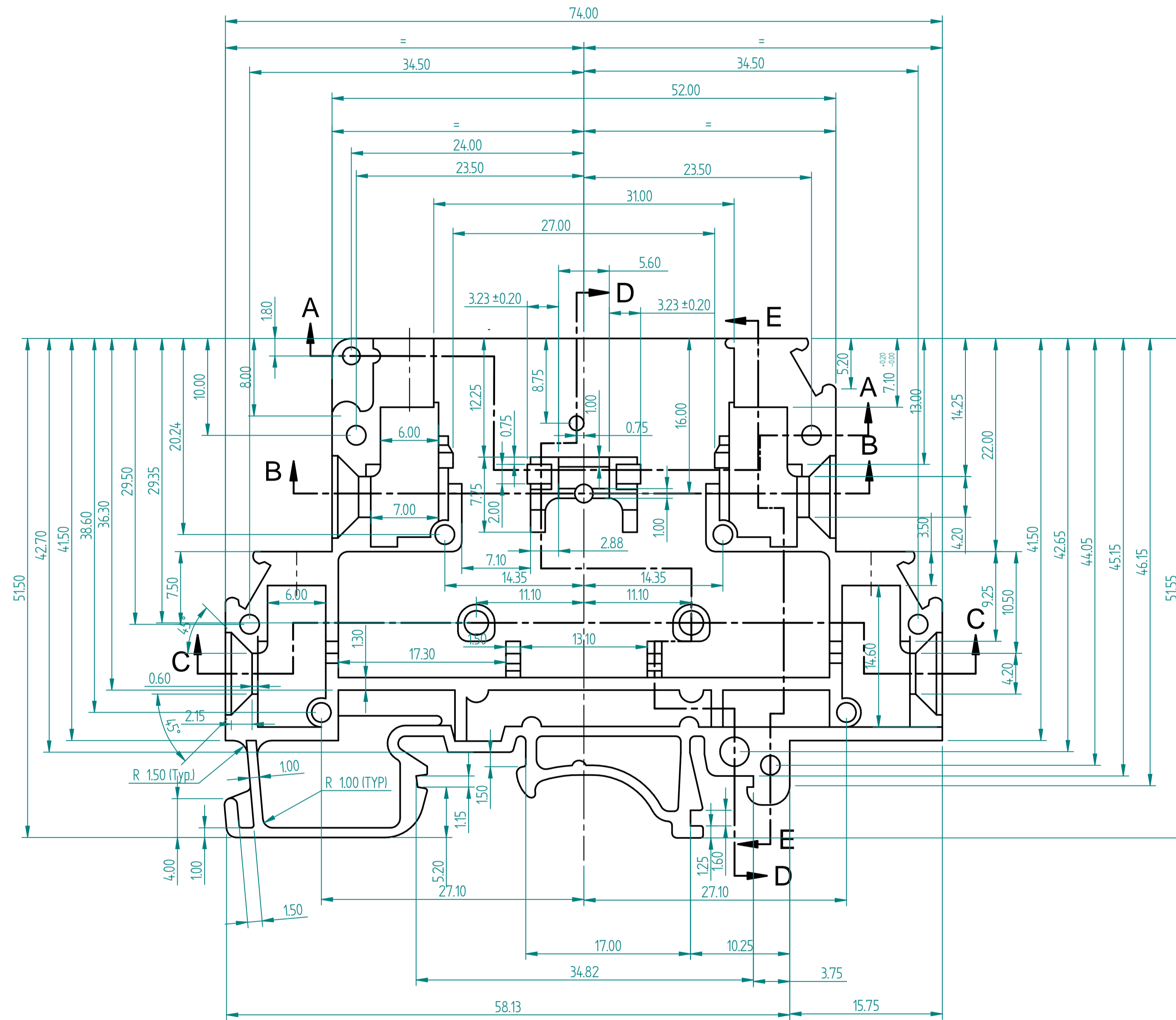

SECTION D-D

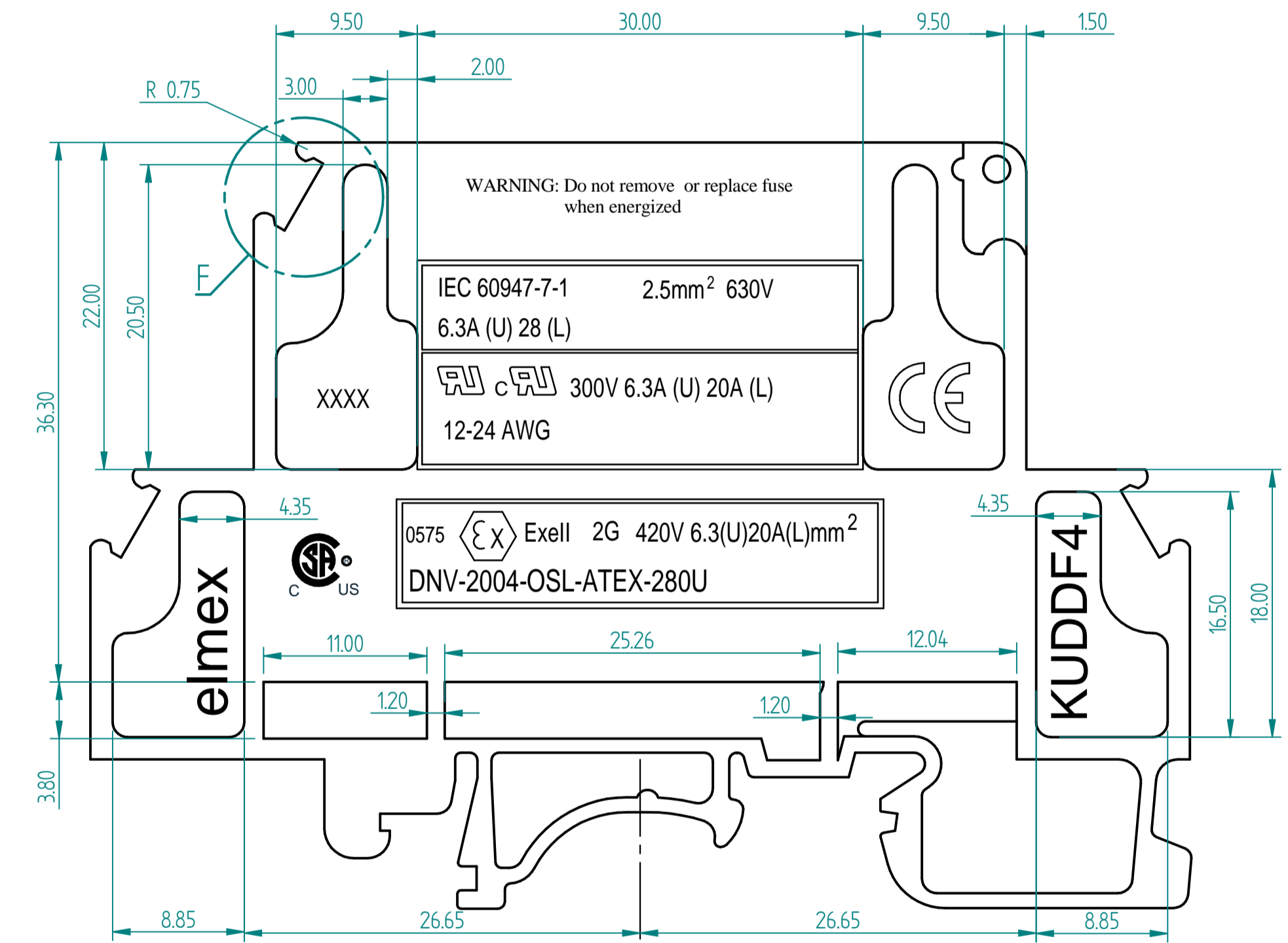

NOTE:- XXXX REFERS TO THE YEAR OF MANUFACTURE.

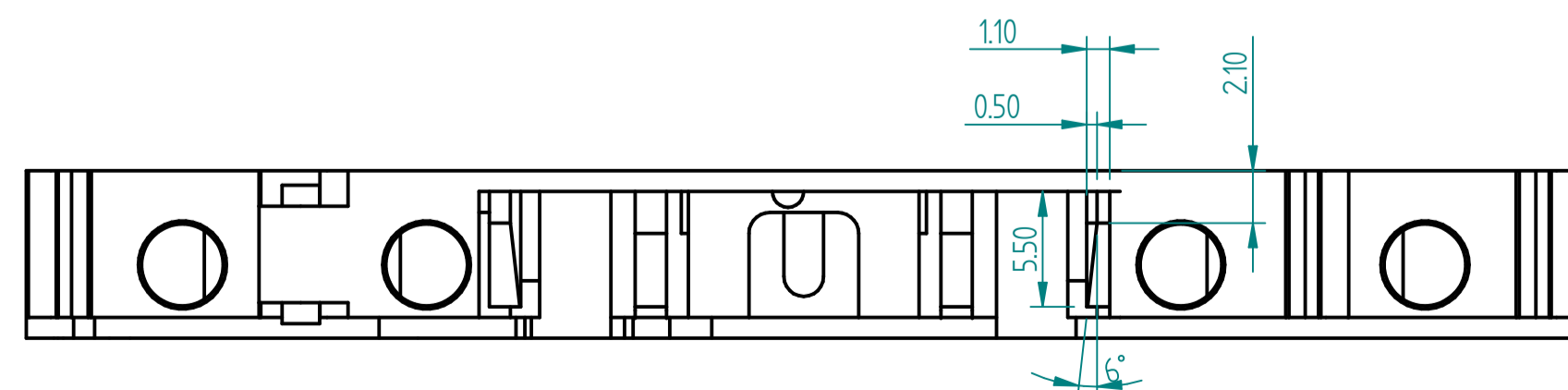

FREE DIMENSION TOLERANCES (REF. DIN 16901)																					
ABOVE	0	1	3	6	10	15	22	30	40	53	70	90	120	160	200	250	315	400	500	630	800
UP TO	1	3	6	10	15	22	30	40	53	70	90	120	160	200	250	315	400	500	630	800	1000
TOLERANCE	±0.10	±0.11	±0.12	±0.14	±0.17	±0.20	±0.24	±0.28	±0.33	±0.40	±0.50	±0.60	±0.75	±0.95	±1.15	±1.45	±1.80	±2.20	±2.80	±3.50	±4.40

REV. No.	3	REVISION DETAIL	20110404	BBP	16-04-2011
IF ANY DOUBT PLEASE ASK	REMOVE ALL SHARP EDGES		ALL DIMENSIONS ARE IN "mm"		
DRAWN BY	JK	DATE	15-06-09	MST No.	029
ENGD BY	BBP	DATE	16-4-2011	FINISH	
APPROVED BY	TR	DATE	16-04-2011	WEIGHT	8.69 g
SCALE	1:1	DESCRIPTION	HOUSING		
SHEET	1 OF 1	DWG. NUMBER	6KUDDF4HN_R03		
					REV 3